

# Code Compliance

Incorporated

Telephone  
352/473-4070

Facsimile  
352/473-1080

---

## REPORT REGARDING CURRENT NATIONAL STANDARDS FOR ENTRAPMENT PREVENTION AND INVESTIGATION OF DUAL-DRAIN, STEVEN'S VENT, U-TUBE VENT PIPE, AND FLORIDA VENT PIPE EMBODIMENTS FOR MITIGATION OF SWIMMING POOL AND SPA DRAIN SUCTION ENTRAPMENT

### ABSTRACT:

This investigation was undertaken on behalf of the Pool Safety Consortium, Inc. (PSC). The PSC is a non-profit corporation that is dedicated to educating code enforcement officials regarding pool and spa safety options that meet recognized and accepted national standards. The purpose and scope of this investigation is to examine and expound upon such standards and to evaluate certain piping arrangements known as "dual drains", "Florida vent pipe", "U-Tube vent pipe", and the "Steven's vent pipe" in order to determine if these embodiments may be relied upon to safely mitigate suction entrapment hazards pursuant to the performance requirements contained within the standards.

### BACKGROUND:

#### Primary Entrapment Hazards:

The industry-wide consensus on the definitions of pool, spa, and wading pool-related entrapment hazards present in these and other recreational bodies of water are identified as follows:

- 1. Body or limb suction entrapment.** A large portion of the body or limb, such as back, stomach, thigh, arm or buttocks is held against a suction outlet as to form a complete seal over the outlet, with or without a cover.
- 2. Hair entrapment.** Long hair is entrained in the flow stream and become knotted, entangled or matted within the outlet cover.
- 3. Mechanical entrapment.** An arm or leg may be trapped where a broken or missing cover/grate is accessible to the bather, or a limb is mechanically lodged in the suction piping. Digits, jewelry, or clothing is entangled, snared, or entrapped in an outlet cover or pool fixture, i.e. ladder, rail, or light.
- 4. Evisceration.** Literally disembowelment. The medical term is "prolapse". This occurs when the buttocks seals the suction outlet. Typically, this devastating injury has occurred in shallow water applications, i.e. wading pools or spas.

#### Standards for Entrapment Avoidance:

There are two primary sectors that are regulated: 1. State Health Codes cover commercial (public) rules, and; 2. State and Local Building codes cover residential (private) rules for safe pool and spa construction. Therefore, authorities having jurisdiction generally delegate enforcement responsibility for commercial (public) pools to the Department of Health, whereas Building Departments have been given jurisdiction over residential (private) pools and spas.

State and local health codes have contained pool and spa safety provisions within the public sector for decades. Entrapments have been largely eliminated within this sector due to the application of water recirculation systems termed, "gravity drainage systems" or "collector tanks". These systems provide recirculation of water within the body of water without using direct pump suction. They utilize drain covers too large to permit a complete seal to be formed against a human body. In addition, flow velocity at the drain cover is limited to flows less than one-and-one-half (1-1/2) feet per second. Some state health codes, however, currently permit "dual drains" as a stand alone method of entrapment avoidance.

# Code Compliance

## Incorporated

### REPORT OF INVESTIGATION

November 30, 2005

---

It is within the private sector where most of the known entrapment related deaths have occurred. In the United States of America, public health and safety within the built-environment is based on state and/or local enforcement of model codes. Numerous state and local authorities having jurisdiction adopt one or more model codes published by the International Code Council (ICC), since in most cases state and local governments do not have the financial and/or technical resources to develop minimum safety standards on their own.

The ICC models are published once every three years on a recurring basis. At this point in time, authorities having jurisdiction have adopted and are beginning to enforce the 2003 set of I-Code models. The *2004 Supplement to the International Building Code (IBC), Section 3109.5, 2003 International Residential Code (IRC), Section AG106*, and subsequent IBC and IRC editions contain minimum safety requirements for the mitigation of pool and spa drain suction entrapment. These provisions are based upon the *United States Consumer Product Safety Commission Publication No. 363 009801*.

---

---

*IMPORTANT NOTE: The following is provided for nonproprietary educational and reference purposes. Copyright © 2004, International Code Council, Inc., Falls Church, VA, 2004 International Residential Code Reproduced with permission. All Rights reserved.*

---

---

#### **2003 IRC SECTION AG106 ENTRAPMENT PROTECTION FOR SWIMMING POOL AND SPA SUCTION OUTLETS<sup>1</sup>**

**AG106.1 General:** *Suction outlets shall be designed to produce circulation throughout the pool or spa. Single outlet systems, such as automatic vacuum cleaner systems, or other such multiple suction outlets whether isolated by valves or otherwise shall be protected against user entrapment.*

**AG106.2 Suction Fittings.** *All Pool and Spa suction outlets shall be provided with a cover that conforms with ANSI/ASME A112.19.8M, or a 12"X 12" drain grate or larger, or an approved channel drain system.*

**Exception:** *Surface skimmers*

**AG106.3 Atmospheric Vacuum Relief System Required.**

*All pool and spa single or multiple outlet circulation systems shall be equipped with atmospheric vacuum relief should grate covers located therein become missing or broken. Such vacuum relief systems shall include at least one approved or engineered method of the type specified herein, as follows:*

- 1. Safety vacuum release system conforming to ASME A112.19.17, or,*
- 2. An approved gravity drainage system*

**AG106.4 Dual Drain Separation.** *Single or multiple pump circulation systems shall be provided with a minimum of two (2) suction outlets of the approved type. A minimum horizontal or vertical distance of three feet (3') shall separate such outlets. These suction outlets shall be piped so that water is drawn through them simultaneously through a vacuum relief-protected line to the pump or pumps.*

**AG106.5 Pool Cleaner Fittings.** *Where provided, vacuum or pressure cleaner fitting(s) shall be located in an accessible position(s) at least (6) inches and not greater than twelve (12) inches below the minimum operational water level or as an attachment to the skimmer(s).*

---

<sup>1</sup>2003 IRC Section IRC AG 106 and IBC Section 3109.5 (2004 Supplement) are identical.

# Code Compliance

## Incorporated

### REPORT OF INVESTIGATION

November 30, 2005

---

The IBC and IRC reference two American National Standards Institute (ANSI)-accredited standards. *ASME A112.19.8M Suction Fittings for Use in Swimming Pools, Wading Pools, Spas and Hot Tubs* and *ASME A112.19.17 Manufactured Safety Vacuum Release Systems (SVRS) for Residential and Commercial Swimming Pool, Spa, Hot Tub and Wading Pool Suction Systems*.

The suction fittings covered in the '19.8 Standard are identified for use in swimming pool, wading pool, spa, hot tub, and whirlpool bathtub appliance installations to provide for a maximum degree of safety from body, mechanical, and hair entrapment. Suction fittings are defined as all components including covers and hardware. The '19.8 standard includes performance testing for structural integrity, ultra-violet light resistance, and hair entrapment resistance.

SVRS Devices covered under the '19.17 standard are designed to prevent high vacuum occurrences that cause human body or limb suction entrapment. The '19.17 standard includes performance requirements for materials, life-cycling, temperature resistance and establishes a "vacuum release rule" that requires a 15 pound buoyant blocking element to be released from a drain under test within an elapsed time of less than three seconds using one-hundred feet of suction piping and one hundred feet of discharge (return) piping loops.

#### **Solutions - Intent of Current Codes:**

Recirculation of water is necessary for maintaining sanitation in pools of water used for recreational and therapeutic purposes, as many harmful pathogens may be passed via multiple human contacts within the contained waters. Recirculation is accomplished using pumps and a network of piping with inlets and outlets to accomplish the desired turnover for maintaining safe levels of sanitizing agents within such waters.

Water has mass and when flowing, velocity. This equals energy. Water is also non-compressible. So there are static and dynamic states and effects that apply to the problem and risk associated with body and limb entrapment. The static conditions relate primarily to the depth of the water (hydrostatic head pressure). The dynamic conditions relate to the velocity of the water, direct versus indirect suction, pressure differentials, pump horsepower, pipe size, and outlet size.

The outlets and pressure differentials are of principal concern relating to the potential for body entrapment. The code provides for three distinct methods that are redundant "layers" for preventing the identified entrapment hazards:

1. The code requires the use of ASME '19.8 covers, or covers equal to or larger than 12" X 12", or approved channel drains.
2. The code requires the use of a vacuum release system when outlets are used for recirculation. This system may be a safety vacuum release system (SVRS) that conforms to the ASME '19.17 standard or an approved gravity drainage system.
3. When ASME '19.8 covers are used, the code requires at least two of the '19.8 covers to be spaced as required (or to be located on two different planes).

Body and limb entrapment is virtually eliminated through the use of gravity drainage [indirect-suction recirculation] systems where flow velocity is required to be less than 1.5 feet per second at the cover/grate or through the use of SVRS for direct suction circulation systems. The potential for body entrapment greatly decreases when a complete seal cannot be formed over a suction outlet cover/grate.

# Code Compliance

## Incorporated

### REPORT OF INVESTIGATION November 30, 2005

---

Where gravity drainage systems are used together with large size cover/grates which cannot be blocked by the "99-percentile man", or with multiple '19.8 suction outlets that do not mount flat and flush with the mounting surface, or with channel drain systems, or when SVRS is used with multiple '19.8 suction outlets that do not mount flat and flush with the mounting surface; the hazard of body and limb entrapment is properly addressed in the model building codes.

The structural tests and fastening requirements included in the ASME '19.8 standard are intended to evaluate the structural integrity of "small" suction fittings, thereby addressing the problem of broken or missing suction cover/grates. Statistics show that missing or broken grates are one leading cause of body and limb entrapments.

The '19.8 standard contains tests intended to reduce the potential of hair entrapment including hair entanglement-resistance performance testing and by establishing maximum allowable flow-rates for listed products. The potential for hair entrapment is virtually eliminated by the use of proper fitted bathing caps.

Mechanical entrapments cannot be entirely prevented since articles of apparel may become entrapped in covers/grates. Most state health codes address this issue by prohibiting jewelry and loose fitting clothing.

#### **Accepted Standards - Conclusions:**

It is the intent of the IRC and IBC to prevent a single direct suction drain opening from being the sole inlet to the suction side of the pump. Portable spas are not part of a structure and therefore are not required to meet the provisions of the codes. However, above-ground pools that utilize drains for recirculation must meet the anti-entrapment provisions of the codes. There is nothing in the code to imply that drains are required for recirculation. All pools and spas that incorporate direct suction systems must incorporate a system that conforms to the *ANSI/ASME A112.19.17* standard. Pools that utilize "gravity drainage systems" or "collector tanks" without direct pump suction or pools that do not utilize drains for recirculation do not require the *ANSI/ASME A112.19.17* certified/listed systems.

#### **INVESTIGATION**

##### **Specifications and Parameters:**

The principal performance requirements utilized herein to investigate and evaluate certain purported safety embodiments are contained in the '19.17 standard: a 15 pound buoyant blocking element must be released from the drain under test within an elapsed time of less than three seconds using one-hundred feet of suction piping and one hundred feet of discharge (return) piping loops. Tests were performed utilizing ½ and 3 horsepower (HP) pumps located 62 inches below the static water level in the test tank.

A test stand was constructed as shown in Figure 1 to hold six feet of water over installed dual drains with three feet separating each drain sump. The drain sump under test has an aggregate cross-sectional (open) area of forty-four (44) square inches. A blocking element that is fifteen pounds buoyant is used to simulate an entrapment event pursuant to the '19.17 standard specification. A full scale, 0-30 inch/Hg pressure (vacuum) transducer capable of acquiring fifty readings each second is used to measure the vacuum condition resulting from a simulated blockage. The transducer is located within the sidewall of the sump under test. A data acquisition system is utilized to plot an inverted transposed waveform graph that shows the resulting vacuum condition of the simulated entrapment event over time. All tests were executed numerous times to insure consistency, repeatability, and accuracy of the resulting plots.

# Code Compliance Incorporated

REPORT OF INVESTIGATION  
November 30, 2005

---

**FIGURE 1. - COMPLETE TEST STAND**

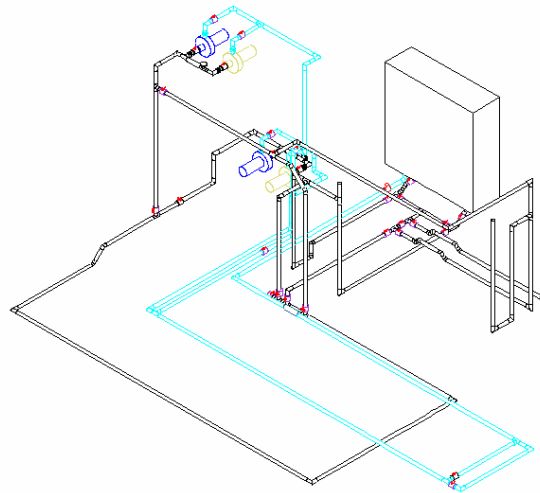

## **Instrumentation:**

Calibrated (A2LA) instrumentation used for tests is listed as follows:

National Instruments Lab-View Data Acquisition Software v7.1

Honeywell/Sensotec Vacuum Transducer(s) Model No. FPV/E437-04 Serial 830572

Flow meter - Sigenet 515 Rotor-X Sensor – Model P51530-PO w/ digital indicator # 3-5075

To establish consistency and repeatability a minimum of three consecutive tests were plotted for each embodiment. However, only one representative plot is included in this report. All tests are conducted indoors and at a conditioned room temperature of approximately 73 Degrees F.

## **Dual Drain Investigation:**

In the following tests dual drains are evaluated utilizing ½ HP and 3HP pumps in accordance with code-referenced standard '19.17. The pumps are located below the static water level in the test tank. Two inch PVC schedule 40 suction and return piping loops are 100' in developed length. The drains are plumbed so that there is three feet of separation between each drain sump. The drain sump subjected to blockage during test has the cover removed. The other sump has a cover secured in place. See Figure 2.

**FIGURE 2. - DUAL  
DRAINS**

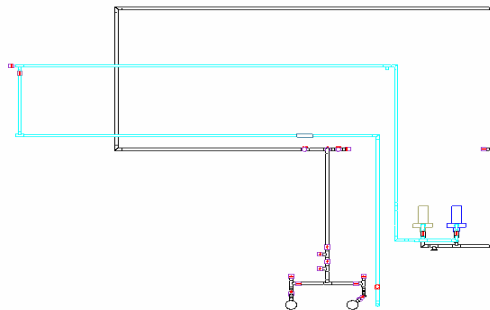

# Code Compliance Incorporated

REPORT OF INVESTIGATION  
November 30, 2005

1. In the first series of tests dual drains are evaluated using a 3 HP pump. One of the dual drains is closed off via a valve and the recorded flow in gallons per minute (gpm) is 78 gpm. The other dual drain is then blocked. Upon the blockage the resulting vacuum condition is plotted as shown in Figure 3. The differential pressure plotted is 32.9 in/HG. This results in an extended dynamic “hold-down” force of 719 pounds.

FIGURE 3.

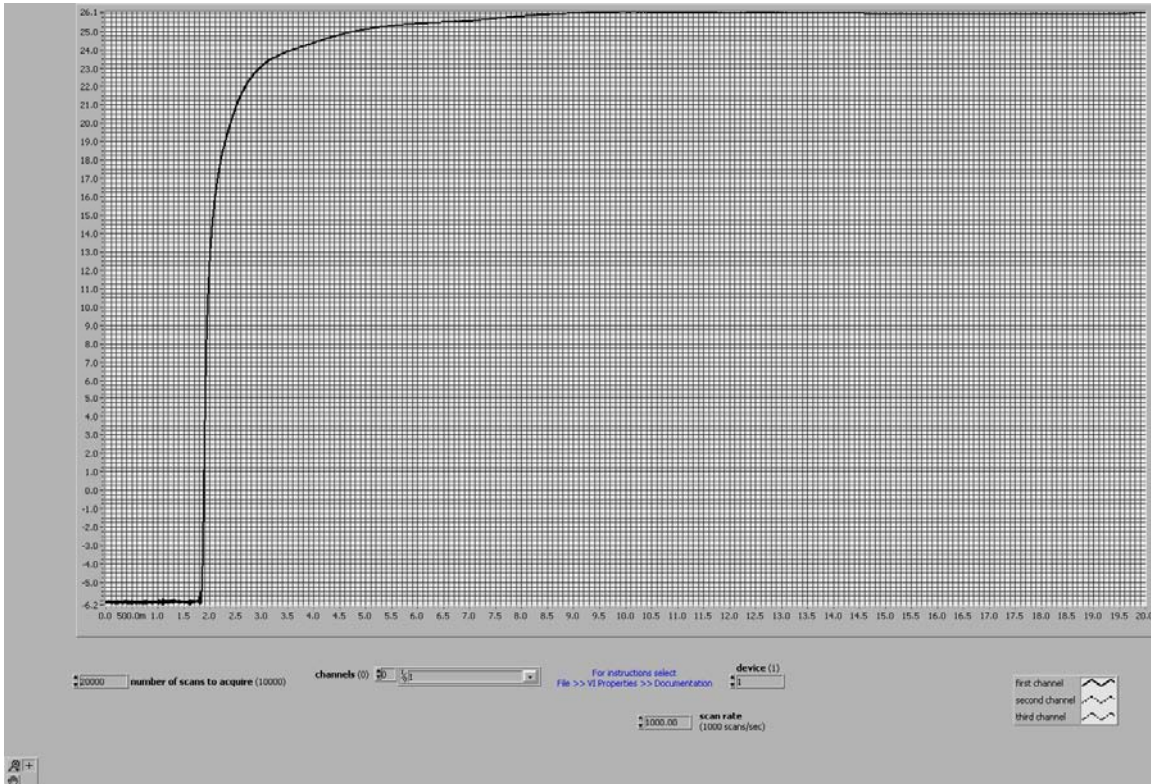

Note: Initial reading at -6.0 in/HG is due to the water depth and the dynamic losses through the sump.

2. In the second series of tests dual drains are evaluated utilizing a ½ HP pump. One of the dual drains is closed off via a valve and the recorded flow is 46 gpm. The other dual drain is then blocked. Upon the blockage the resulting vacuum condition is plotted as shown in Figure 4. The differential pressure plotted is 31.0 in/HG. This results in an extended dynamic “hold-down” force of 677 pounds.

3. In the third series of tests dual drains are evaluated utilizing a 3 HP pump. With both of the dual drains open and flowing at 78 gpm the other dual drain is then blocked. Upon the blockage the resulting vacuum condition is plotted as shown in Figure 5. The differential pressure plotted is 3.0 in/HG. This results in an extended dynamic “hold-down” force of 65 pounds.

4. In the fourth series of tests dual drains are evaluated utilizing a ½ HP pump. With both of the dual drains open and flowing at 46 gpm the other dual drain is then blocked. Upon the blockage the resulting vacuum condition is plotted as shown in Figure 6. The differential pressure plotted is 1.30 in/HG. This results in a dynamic “hold-down” force of 28 pounds.

# Code Compliance Incorporated

REPORT OF INVESTIGATION  
November 30, 2005

FIGURE 4.

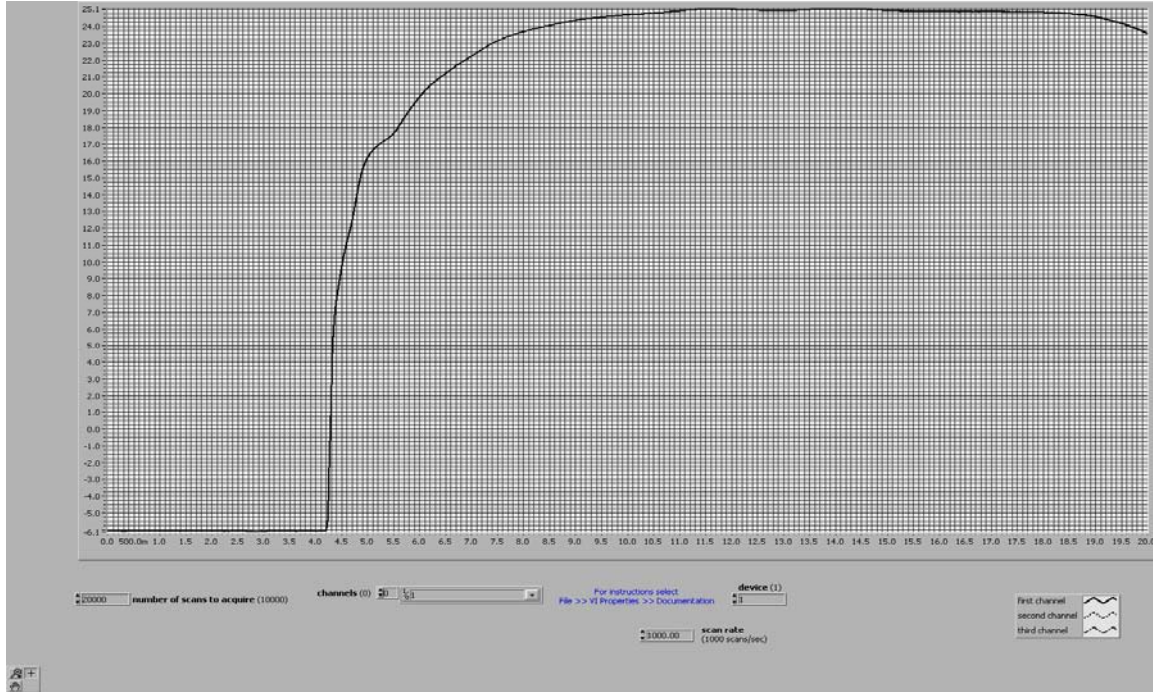

FIGURE 5.

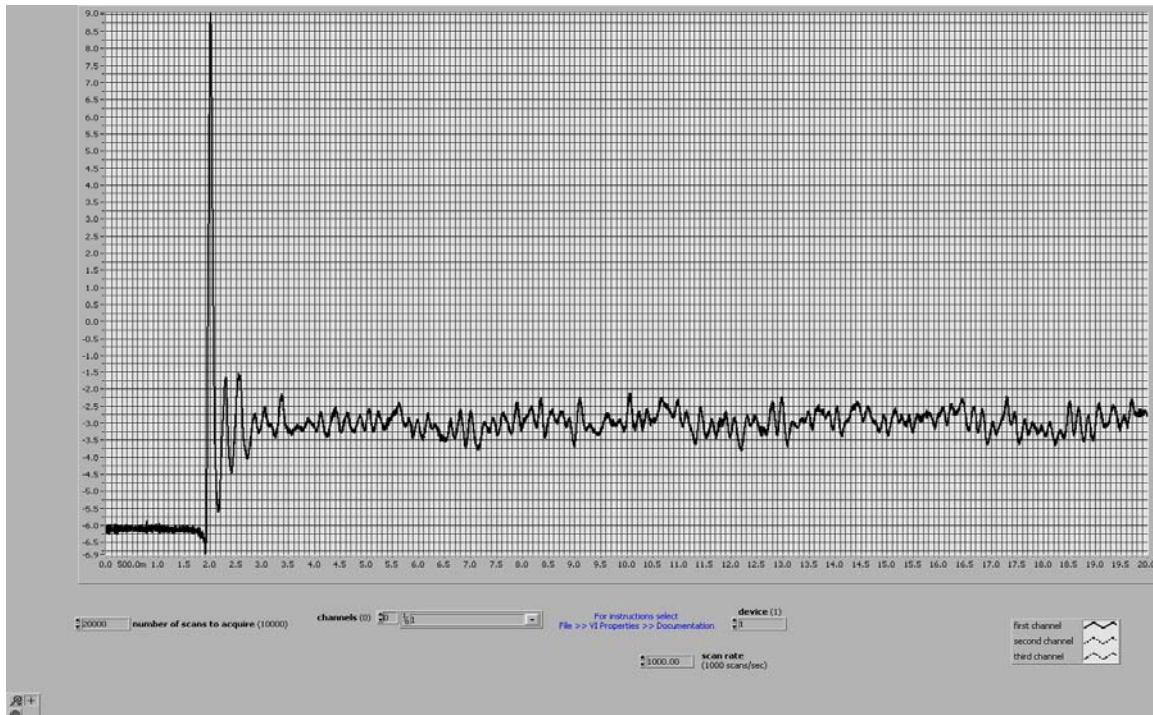
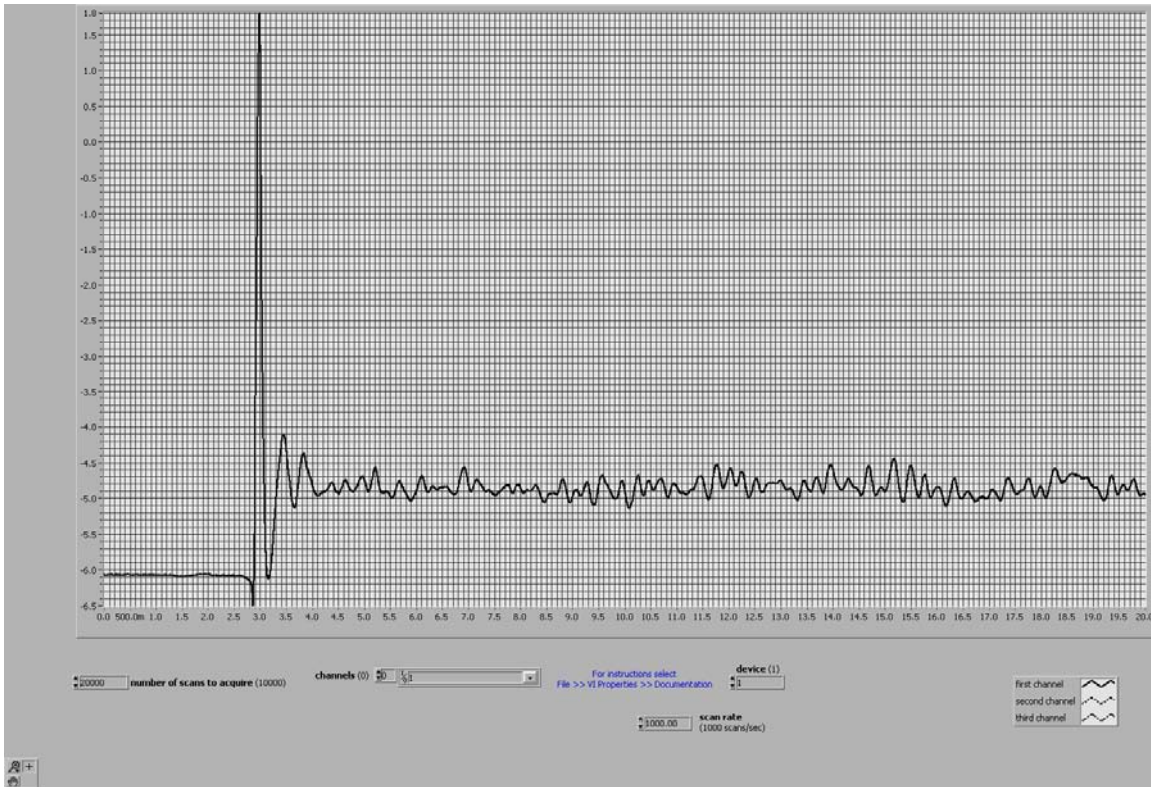

FIGURE 6.



**Conclusions – Dual Drain Investigation:**

If dual drains were the only means of entrapment prevention relied upon and one of the two drains were to become blocked due to leaves, trash, pool toys or otherwise, then the other drain would have an entrapment force of 719 pounds for a 3 HP pump and 677 pounds for a ½ HP pump. If a small child were to seal one drain, with the opposite drain open and flowing, the “hold-down” force is 65 pounds at 78 gpm and 28 pounds at 46 gpm.

Therefore, dual drains as a stand alone method cannot be safely relied upon for entrapment prevention given the potential for drain blockage and excessive dynamic suction forces.

**Florida Vent Investigation:**

In the following tests the Florida vent system together with dual drains is evaluated utilizing ½ HP and 3HP pumps in accordance with code-referenced standard ‘19.17. The pump is located below the static water level in the test tank. Two inch PVC schedule 40 suction and return piping loops are 100’ in developed length. The drains are plumbed so that there is three feet of separation between each drain sump. The drain sump subjected to blockage during the test has the cover removed. The other sump has a cover secured in place. See Figure 7.



**FIGURE 7. – FLORIDA VENT SYSTEM W/DUAL DRAINS**

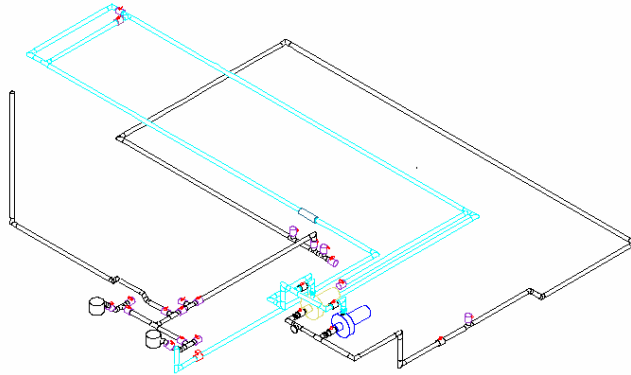

1. In the first series of tests the Florida Vent system is evaluated together with dual drains utilizing a 3HP pump. When at rest, the level of water in the vent pipe portion of the Florida vent system is equal to the water level in the test tank, as shown in Figure 7-1. One of the dual drains is closed off via a valve. After starting the 3 HP pump, the water level in the vent is allowed to stabilize and as such the recorded gallon per minute (gpm) flow is 78 gpm. The “operating draw-down” is at 60 inches, as shown in Figure 7-2. The other dual drain is then blocked.

The vent pipe empties and air enters the suction piping, as shown in Figure 7-3. The blocking element failed to release within the required time. The pump was shut off and the element did not release until over one minute had elapsed. The differential pressure plotted is 5.2 in/HG, as shown in Figure 7-4. This results in an extended static differential “hold-down” force of 114 pounds.

**FIGURE 7-1**

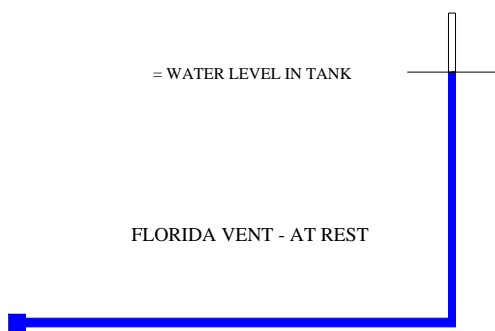

**FIGURE 7-2**

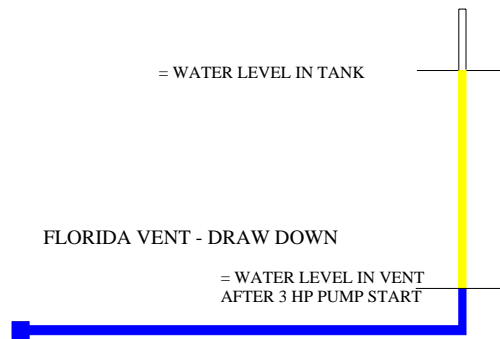

# Code Compliance Incorporated

REPORT OF INVESTIGATION  
November 30, 2005

FIGURE 7-3.

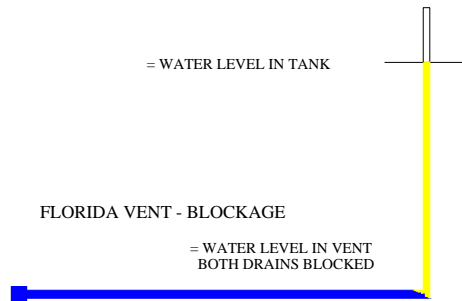
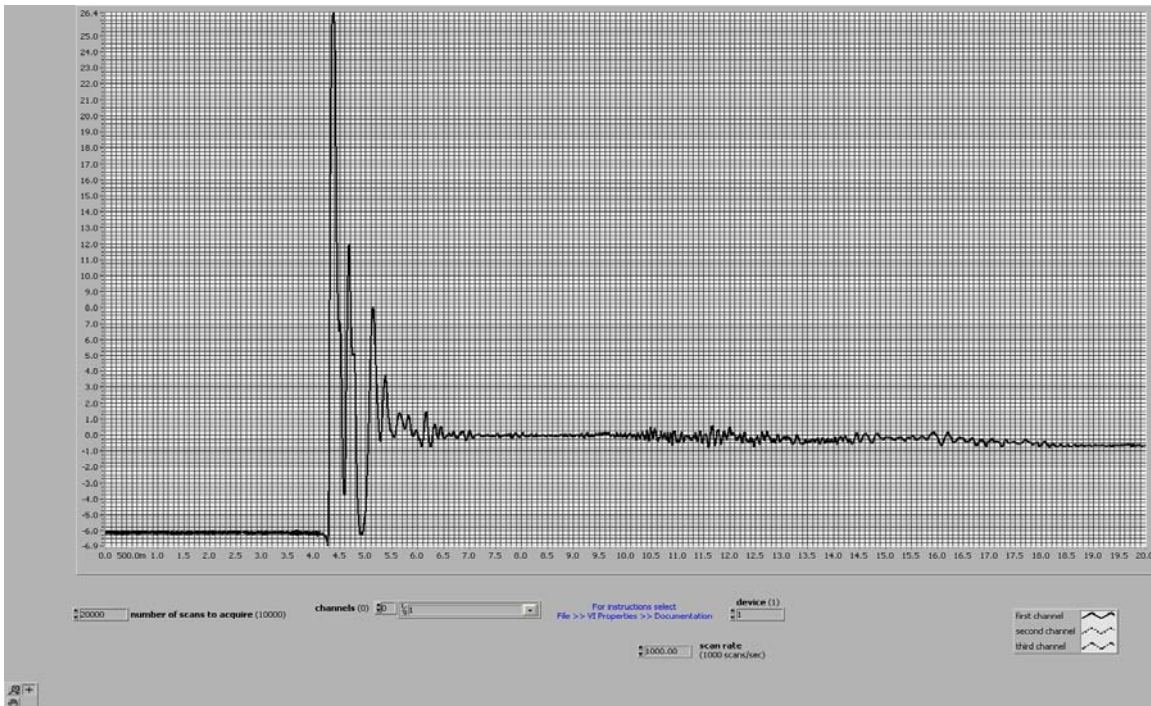

FIGURE 7-4.



2. In the second series of tests, the Florida Vent system is evaluated together with dual drains utilizing a  $\frac{1}{2}$  HP pump. The level of water in the vent pipe portion of the Florida Vent system, when at rest, is equal to the water level in the test tank, as shown in Figure 7-5. One of the dual drains is closed off via a valve. After starting the  $\frac{1}{2}$  HP pump the water level in the vent is allowed to stabilize and as such the recorded flow is 44 gpm. The “operating draw-down” is at 20.5 inches, as shown in Figure 7-6. The other dual drain is then blocked.

The vent pipe empties and air enters the suction piping, as shown in Figure 7-7. The blocking element failed to release within the required time. The pump was shut off and the element did not release until over one minute had elapsed. The differential pressure plotted is 5.2 in/HG. This results in an extended static differential “hold-down” force of 114 pounds, as shown in Figure 7-8.

# Code Compliance Incorporated

REPORT OF INVESTIGATION  
November 30, 2005

---

**FIGURE 7-5.**

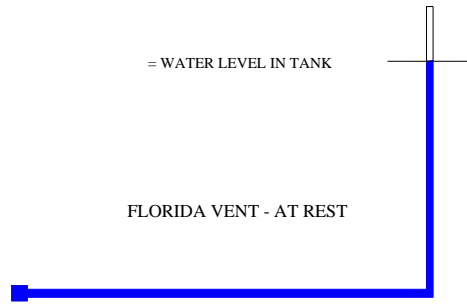

**FIGURE 7-6.**

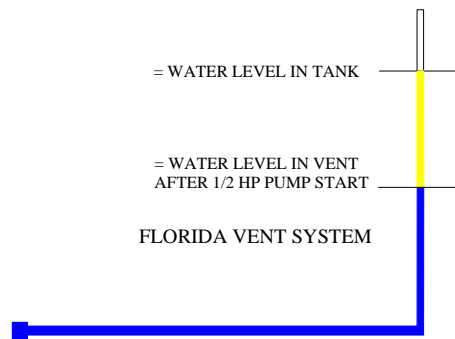

**FIGURE 7-7.**

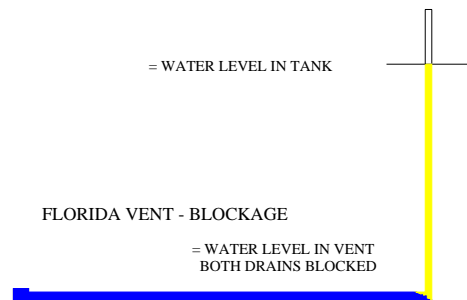

# Code Compliance Incorporated

REPORT OF INVESTIGATION  
November 30, 2005

FIGURE 7-8.

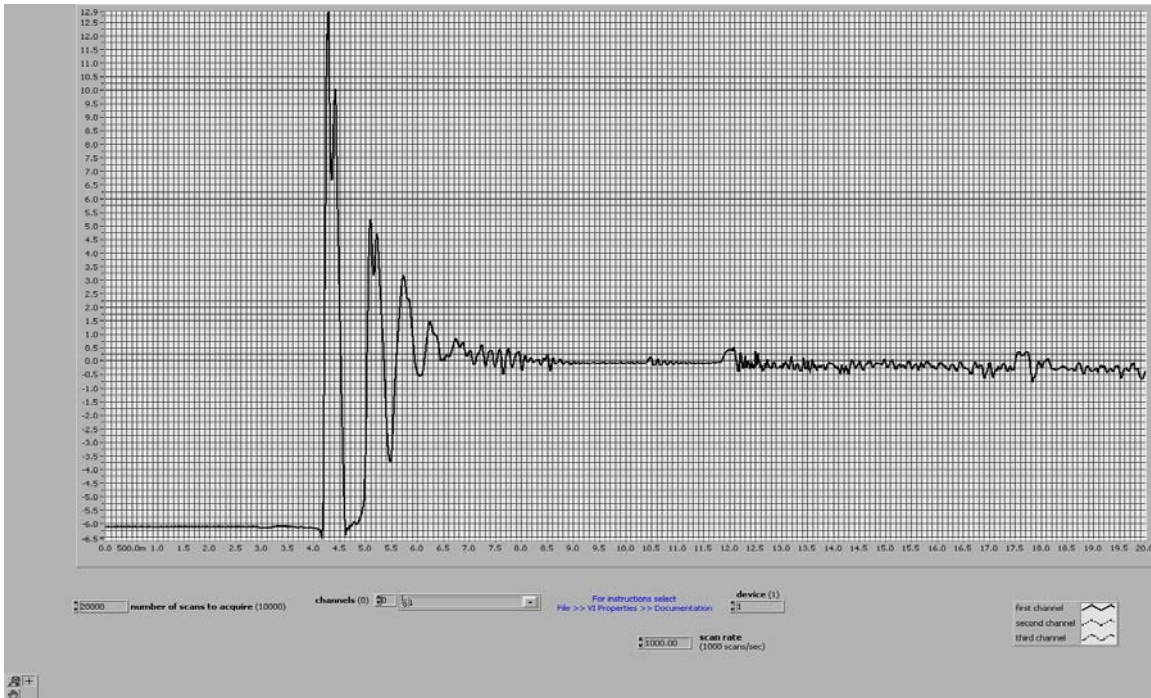

3. In the third series of tests the Florida Vent system is evaluated utilizing a 3 HP pump. When at rest, the level of water in the vent pipe portion of the Florida vent system is equal to the water level in the test tank, as shown in Figure 7-9. After starting the 3 HP pump, the water level in the vent is allowed to stabilize and as such the recorded flow is 78 gpm. The “operating draw-down” is at 27 inches, as shown in Figure 7-10. With both of the dual drains open and flowing the other dual drain is then blocked. The “draw-down” upon the blockage is 63 inches, as shown in Figure 7-11. Upon the blockage the resulting vacuum condition is plotted as shown in Figure 7-12. The differential pressure plotted is 3.0 in/HG. The result is an extended dynamic “hold-down” force of 65 pounds.

FIGURE 7-9.

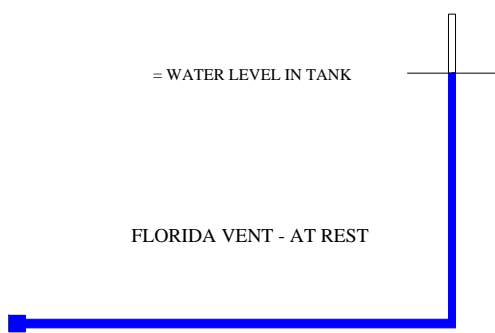
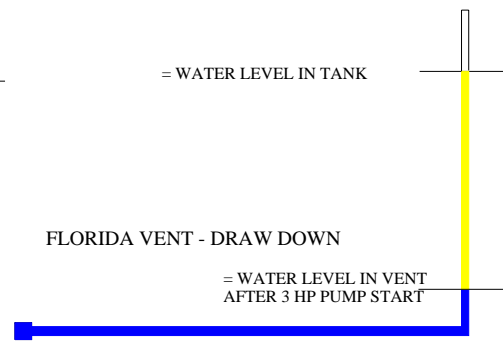

FIGURE 7-10.



# Code Compliance Incorporated

REPORT OF INVESTIGATION  
November 30, 2005

FIGURE 7-11.

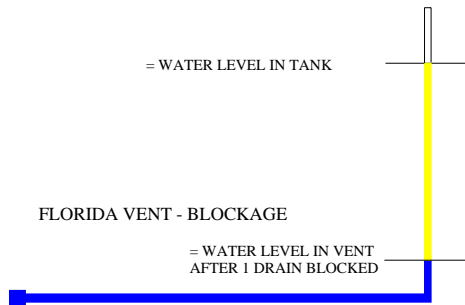
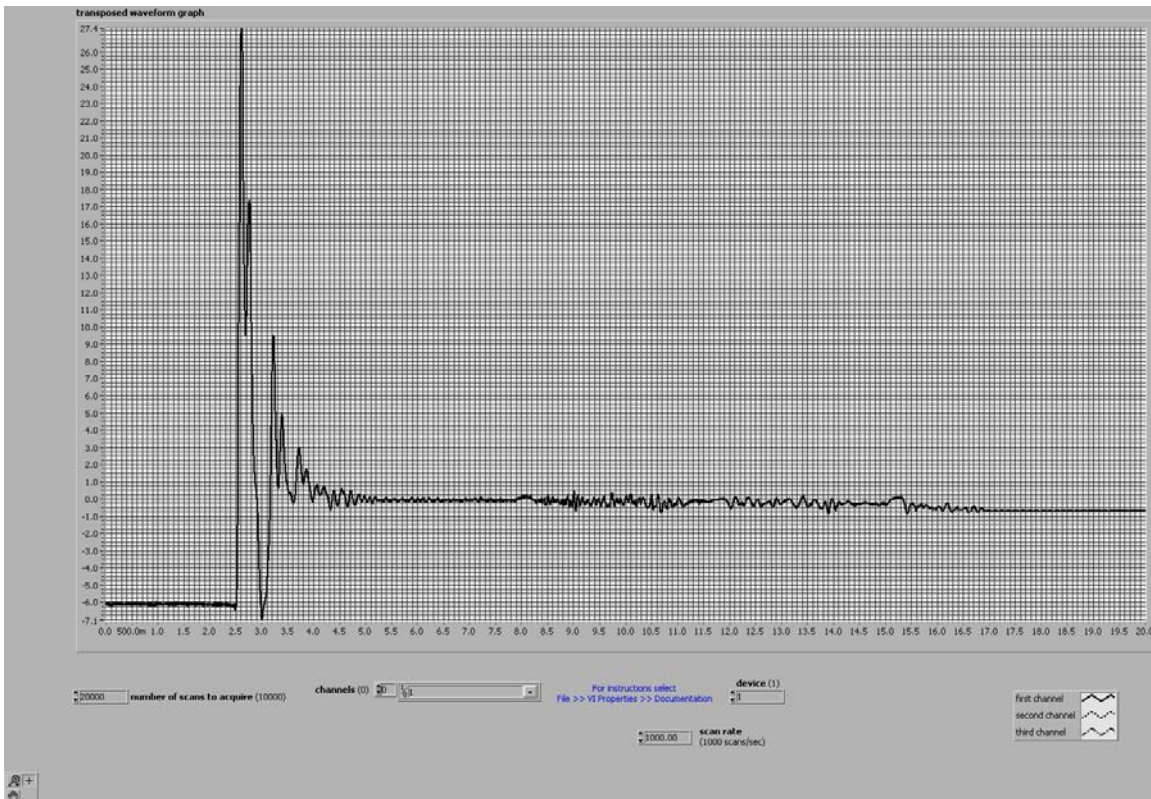

FIGURE 7-12.



4. In the fourth series of tests the Florida vent system is evaluated utilizing a ½ HP pump. When at rest, the level of water in the vent pipe portion of the Florida vent system is equal to the water level in the test tank, as shown in Figure 7-13.

After starting the 1/2 HP pump, the water level in the vent is allowed to stabilize and as such the recorded flow is 44 gpm. The “operating draw-down” is at 10 inches, as shown in Figure 7-14. With both of the dual drains open and flowing the other dual drain is then blocked. The “draw-down” upon the blockage is 20.5 inches, as shown in Figure 7-15. Upon the blockage the resulting vacuum condition is plotted as shown in Figure 7-16. The differential pressure plotted is 1.30 in/HG. This results in an extended “hold-down” force of 28.0 pounds.

# Code Compliance Incorporated

REPORT OF INVESTIGATION  
November 30, 2005

**FIGURE 7-13.**

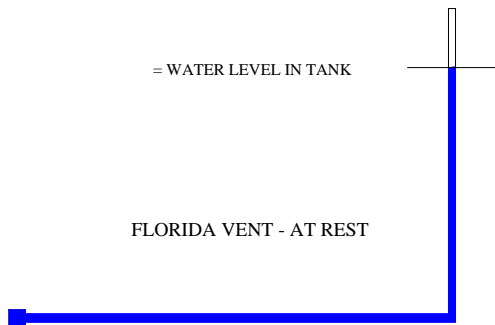

**FIGURE 7-14.**

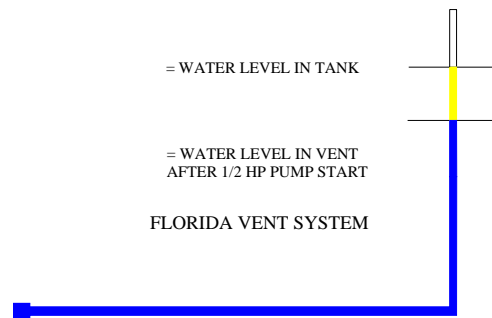

**FIGURE 7-15.**

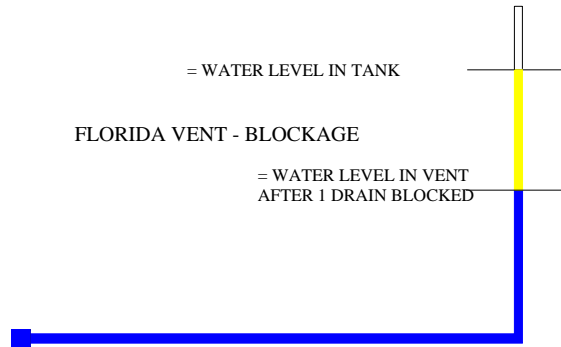

**FIGURE 7-16.**

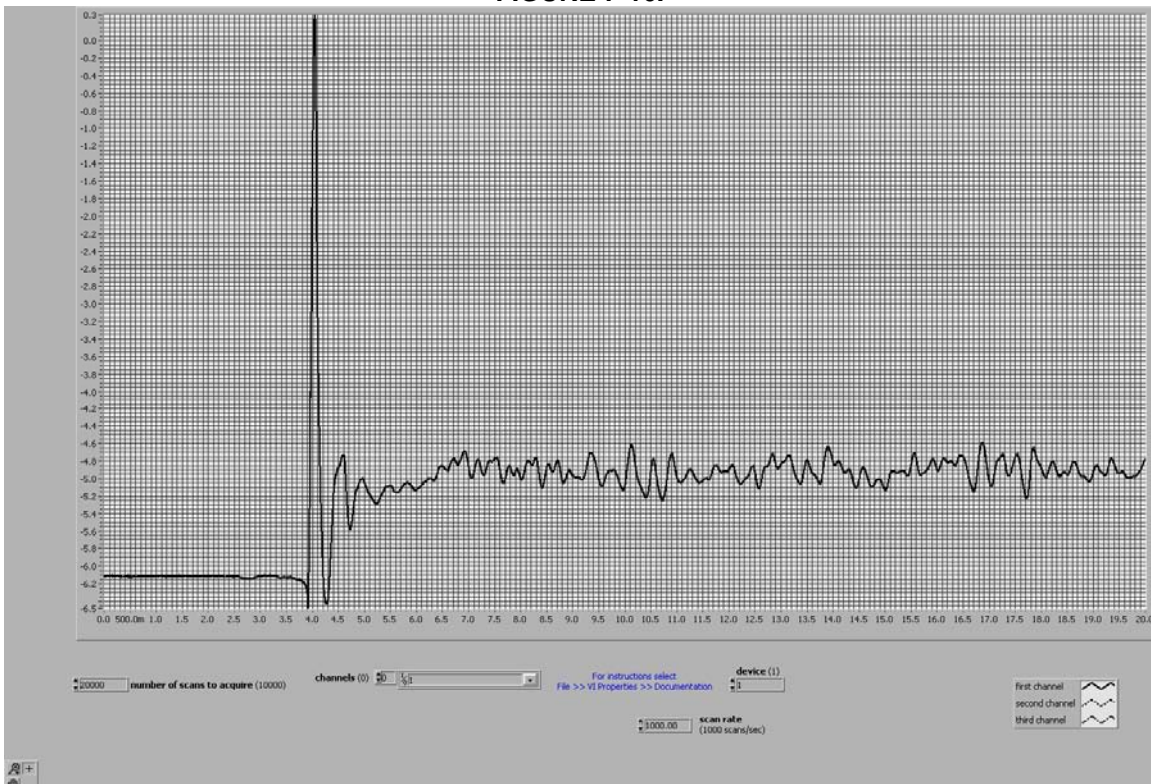

# Code Compliance Incorporated

REPORT OF INVESTIGATION  
November 30, 2005

---

## Conclusions – Florida Vent System Investigation:

If the Florida vent system together with dual drains were the only means of entrapment prevention and one of the two drains were to become blocked due to leaves, trash, pool toys or otherwise, then the other drain has a static differential entrapment force of 114 pounds, at six feet pool depth on a standard eight inch, uncovered sump. If a small child were to seal one drain, with the opposite drain open and flowing, the dynamic “hold down” force would be 65 pounds at 78 gpm and 28 pounds at 44 gpm. Therefore, The Florida vent system together with dual drains cannot be safely relied upon for entrapment prevention given the potential for excessive dynamic and static “hold down” forces.

## U-Tube Vent System Investigation:

In the following tests, dual drains are evaluated utilizing ½ HP and 3HP pumps in accordance with code-referenced standard ‘19.17. The pumps are located below the static water level in the test tank. Two inch PVC schedule 40 suction and return piping loops are 100’ in developed length. The drains are plumbed so that there is three feet of separation between each drain sump. The drain sump subjected to blockage during test has the cover removed. The other sump has a cover secured in place. See Figure 8.

1. In the first series of tests, the U-Tube Vent system is evaluated together with dual drains utilizing a 3HP pump, as shown in Figure 8. One of the dual drains is closed off via a valve. When at rest, the level of water in the vent pipe portion of the U-Tube vent system is equal to the water level in the test tank, as shown in Figure 8-1. After starting the 3 HP pump, the water level in the vent is allowed to stabilize and the recorded flow is 61 gpm. The “operating draw-down” is at 78 inches, as shown in Figure 8-2. The other dual drain is then blocked.

The U-Tube vent pipe empties and air enters the suction piping, as shown in Figure 8-3. The blocking element is released within the required time, as shown in Figure 8-4.

**FIGURE 8. – U-TUBE VENT SYSTEM W/DUAL DRAINS**

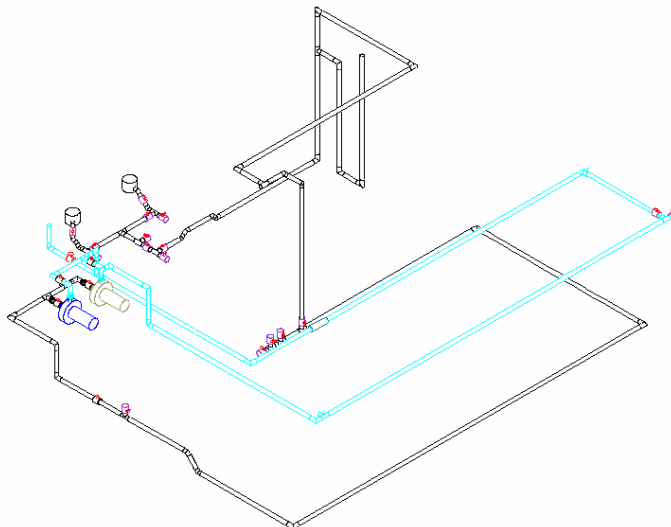

# Code Compliance Incorporated

REPORT OF INVESTIGATION  
November 30, 2005

---

**FIGURE 8-1.**

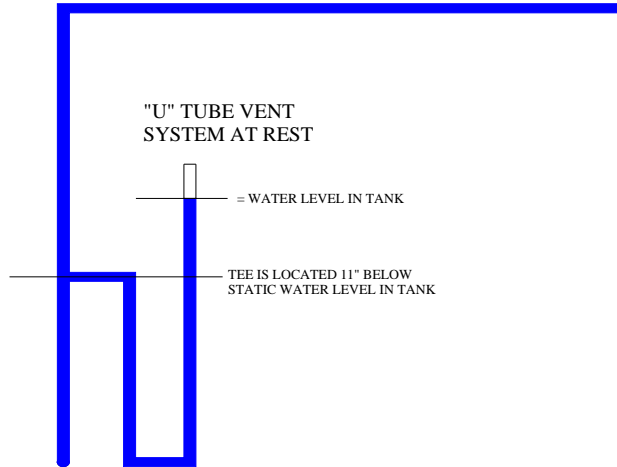

**FIGURE 8-2.**

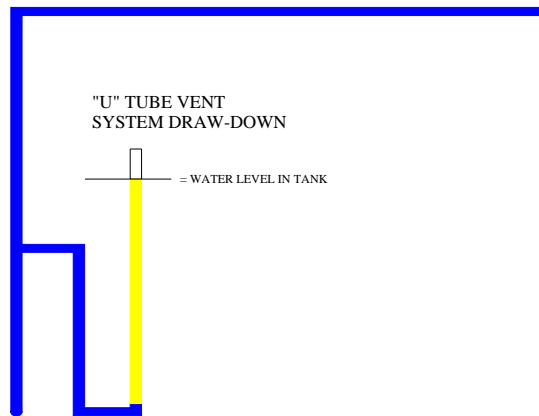

**FIGURE 8-3.**

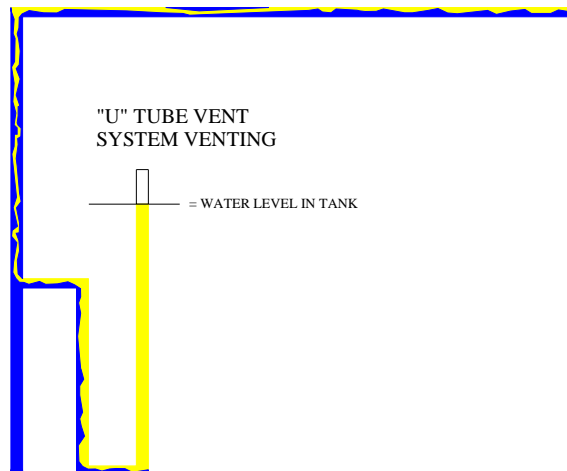
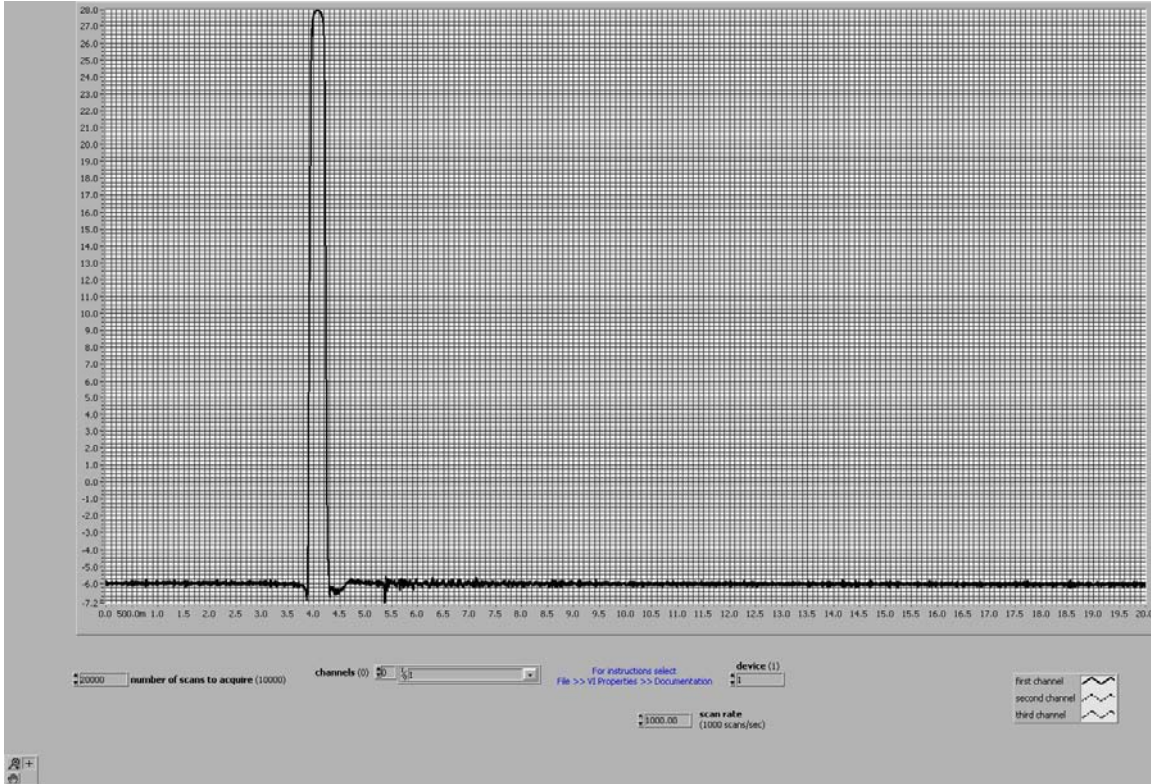



FIGURE 8-4.



2. In the second series of tests the U-Tube Vent system is evaluated together with dual drains utilizing a ½ HP pump, as shown in Figure 8. One of the dual drains is closed off via a valve. When at rest, the level of water in the vent pipe portion of the U-Tube vent system is equal to the water level in the test tank, as shown in Figure 8-5. After starting the ½ HP pump the water level in the vent is allowed to stabilize and as such the recorded flow is 44 gpm. The “operating draw-down” is at 41 inches, as shown in Figure 8-6. The other dual drain is then blocked.

FIGURE 8-5.

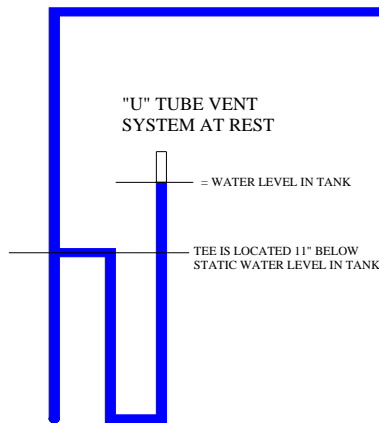
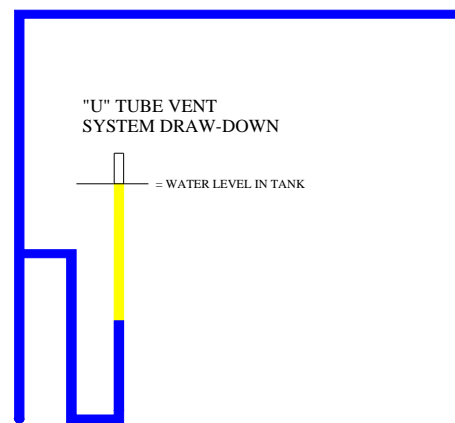

FIGURE 8-6.



# Code Compliance Incorporated

REPORT OF INVESTIGATION  
November 30, 2005

FIGURE 8-7.

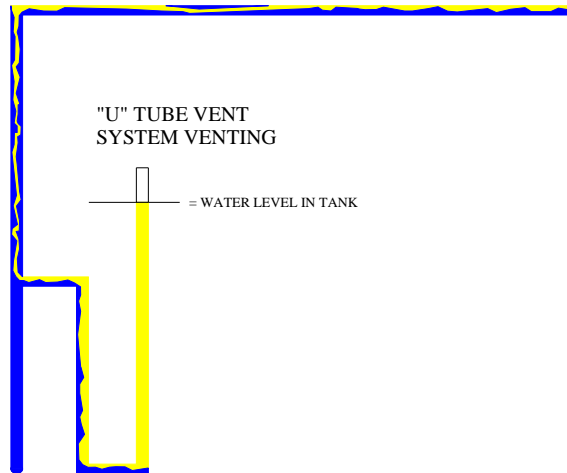
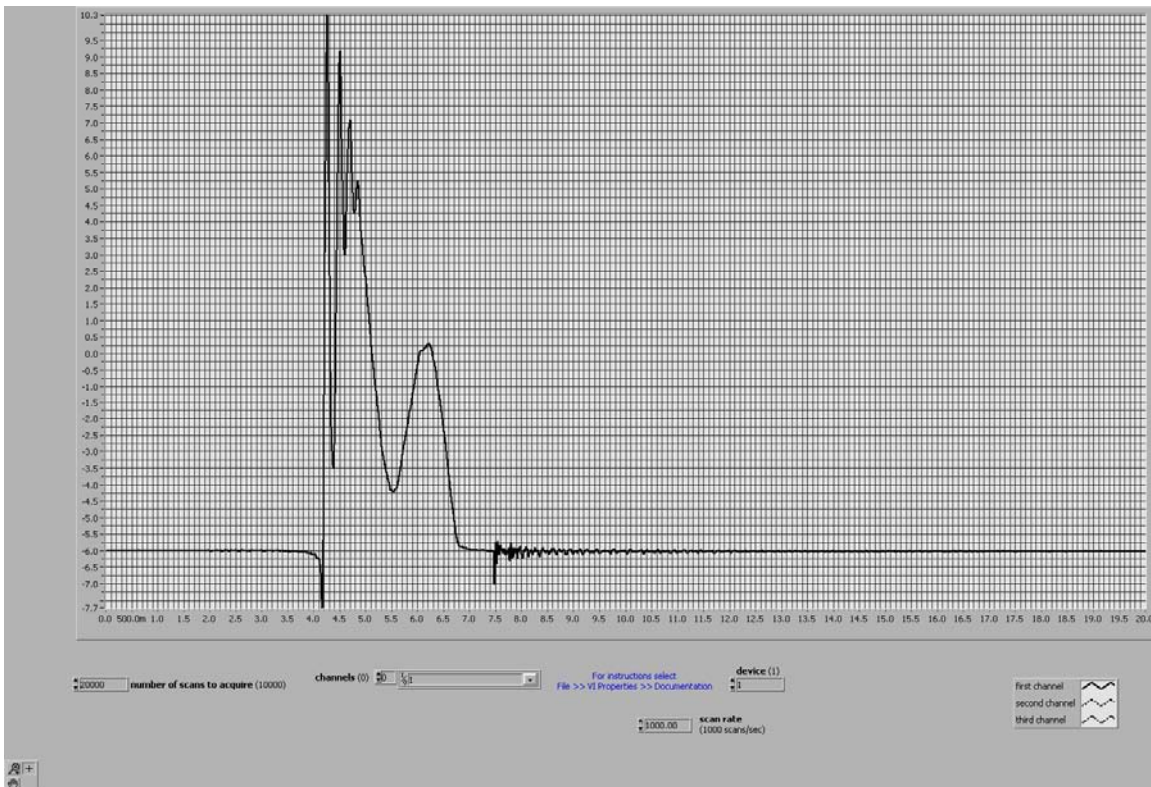

FIGURE 8-8.



The U-Tube vent pipe empties and air enters the suction piping, as shown in Figure 8-7. The blocking is released within the required time, as shown in Figure 8-8.

# Code Compliance Incorporated

REPORT OF INVESTIGATION  
November 30, 2005

---

3. In the third series of tests the U-Tube Vent system is evaluated together with dual drains utilizing a 3HP pump, as shown in Figure 8. When at rest, the level of water in the vent pipe portion of the U-Tube vent system is equal to the water level in the test tank, as shown in Figure 8-9. After starting the 3 HP pump, the water level in the vent is allowed to stabilize and as such the recorded flow is 72 gpm. The "operating draw-down" is at 78 inches, as shown in Figure 8-10. With both of the dual drains open and flowing the other dual drain is then blocked.

The U-Tube vent pipe empties and air enters the suction piping, as shown in Figure 8-11. The blocking element does not release within the required time, as shown in Figure 8-12. The release time or time to return to zero differential is 3.7 seconds.

FIGURE 8-9.

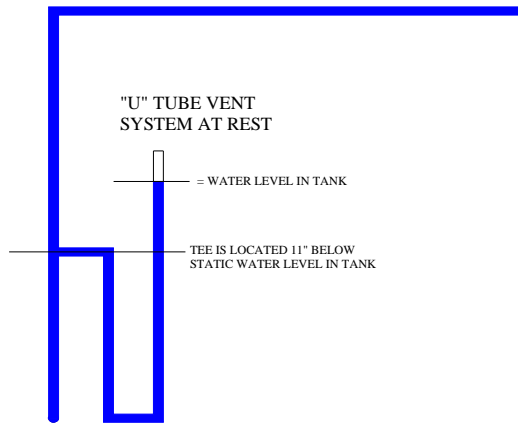

FIGURE 8-10

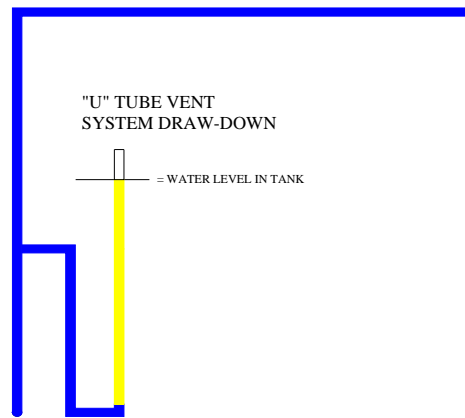
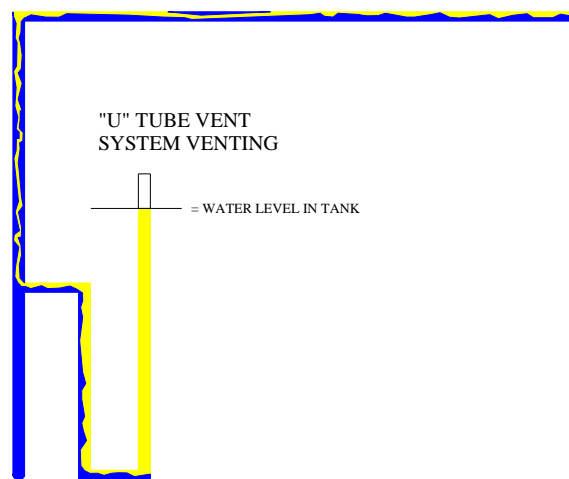

FIGURE 8-11.



# Code Compliance Incorporated

REPORT OF INVESTIGATION  
November 30, 2005

FIGURE 8-12.

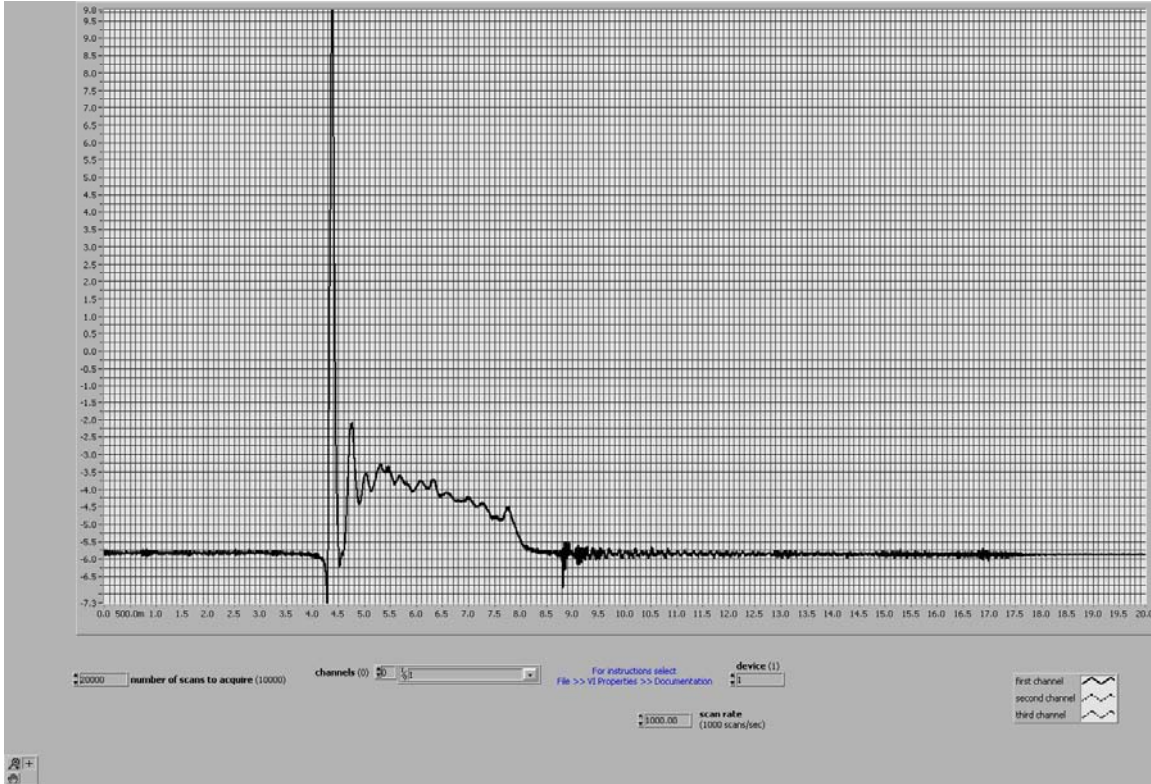

4. In the fourth series of tests the U-Tube Vent system is evaluated together with dual drains utilizing a ½ HP pump, as shown in Figure 8. When at rest, the level of water in the vent pipe portion of the U-Tube vent system is equal to the water level in the test tank, as shown in Figure 8-13. After starting the ½ HP pump, the water level in the vent is allowed to stabilize and as such the recorded flow is 42 gpm. The “operating draw-down” is at 31 inches, as shown in Figure 8-14. With both of the dual drains open and flowing the other dual drain is then blocked. The U-Tube vent pipe does not vent, as shown in Figure 8-15. The draw down upon the blockage is 42 inches. However, the blocking element was released within the required time, as shown in Figure 8-16.

FIGURE 8-13.

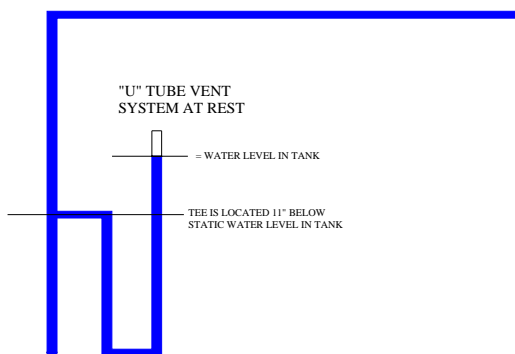
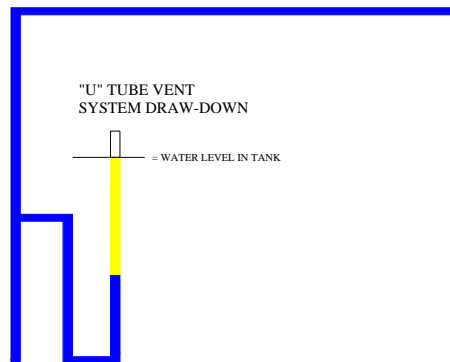

FIGURE 8-14.



# Code Compliance Incorporated

REPORT OF INVESTIGATION  
November 30, 2005

FIGURE 8-15.

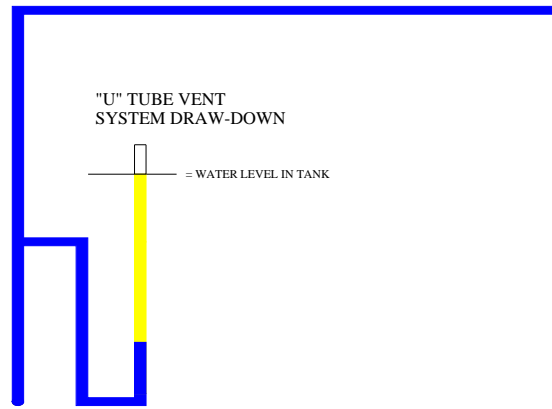
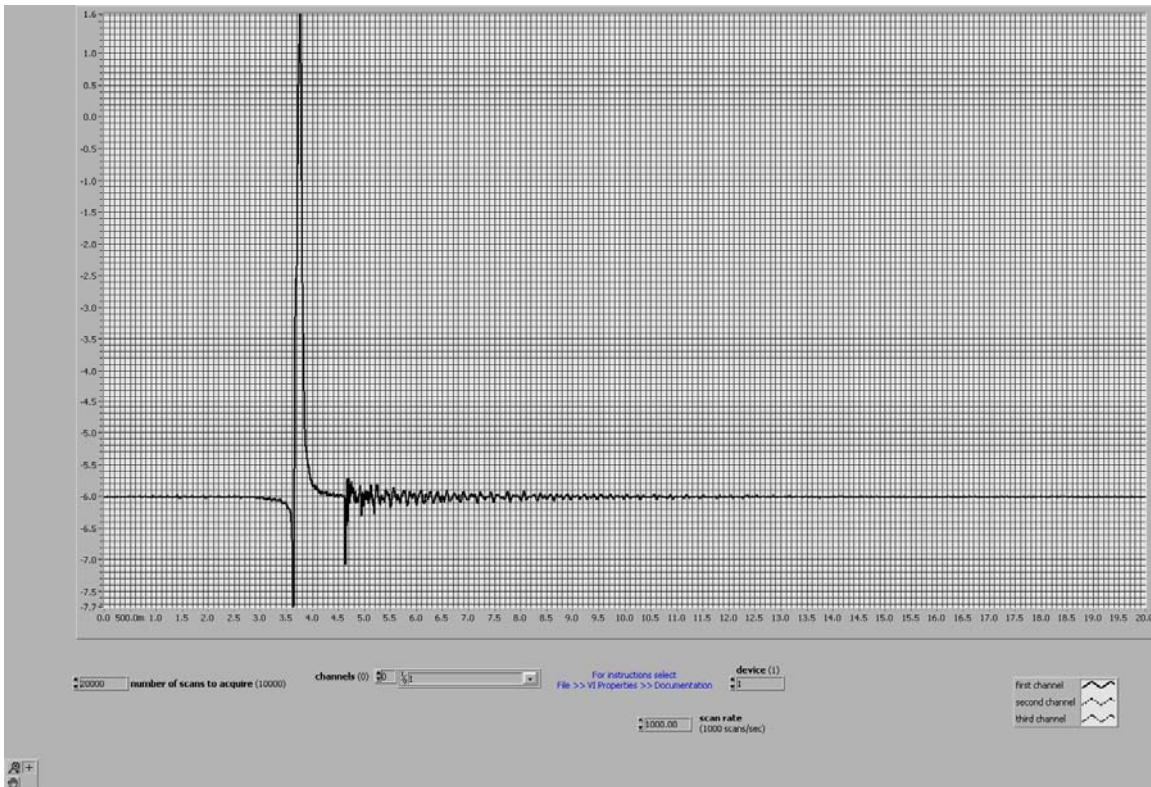

FIGURE 8-16.



## Conclusions – U-Tube Vent Investigation:

The U-Tube vent system together with dual drains performs in accordance with the accepted standards by releasing the blocking element within the required time for the test conditions 1, 2, and 4. The U-Tube vent system with dual drains fails to meet the standard for test condition 3. In all cases, the pumps would not re-prime between each test. The only way to re-prime the pumps was to manually bleed off the air that remained in the suction piping. Note: One of the ½ HP pumps “burned-out” during the series of tests and had to be replaced.

# Code Compliance Incorporated

REPORT OF INVESTIGATION  
November 30, 2005

---

## Steven's Vent System Investigation:

In the following tests, the Steven's vent system together with dual drains is evaluated utilizing  $\frac{1}{2}$  HP and 3HP pumps in accordance with code-referenced standard '19.17. The pump is located below the static water level in the test tank. Two inch PVC schedule 40 suction and return piping loops are 100' in developed length. The drains are plumbed so that there is three feet of separation between each drain sump. The drain sump subjected to blockage during the test has the cover removed. The other sump has a cover secured in place. See Figure 9.

**FIGURE 9. – STEVEN'S VENT SYSTEM**

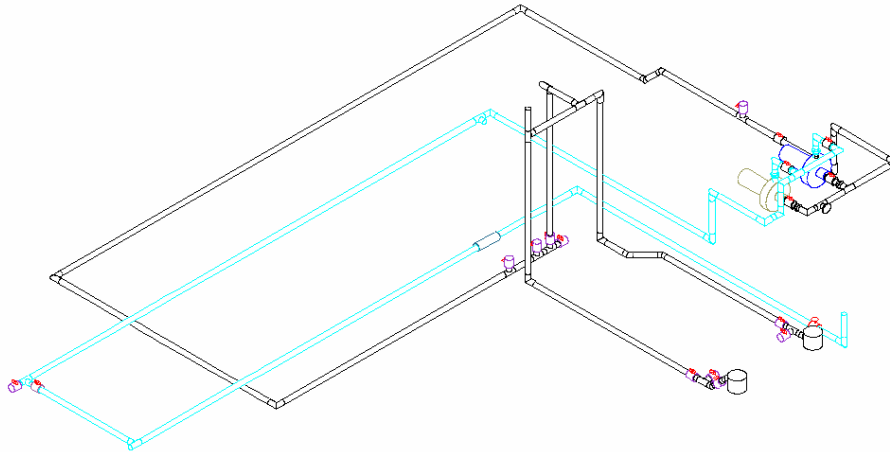

1. In the first series of tests the Steven's Vent system is evaluated together with dual drains utilizing a 3HP pump, as shown in Figure 9. One of the dual drains is closed off via a valve. When at rest, the level of water in the vent pipe portion of the Steven's vent system is equal to the water level in the test tank, as shown in Figure 9-1. After starting the 3 HP pump, the water level in the vent is allowed to stabilize and as such the recorded flow is 44 gpm. The "operating draw-down" is at 10 inches, as shown in Figure 9-2. The other dual drain is then blocked.

**FIGURE 9-1.**

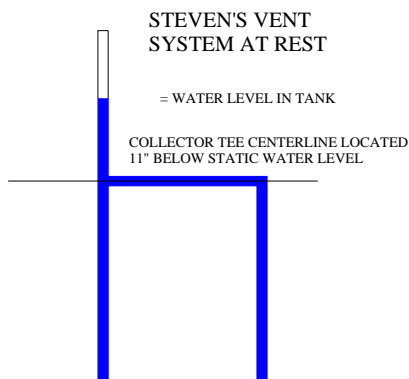

**FIGURE 9-2.**  
STEVEN'S VENT  
OPERATING DRAW-DOWN

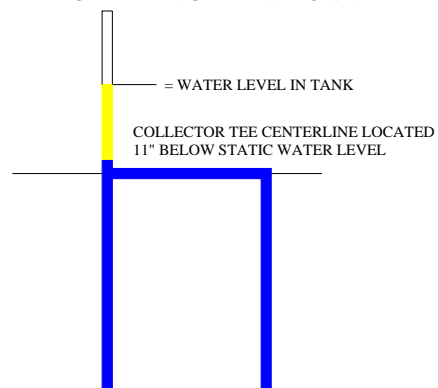

# Code Compliance Incorporated

REPORT OF INVESTIGATION  
November 30, 2005

---

**FIGURE 9-3.**

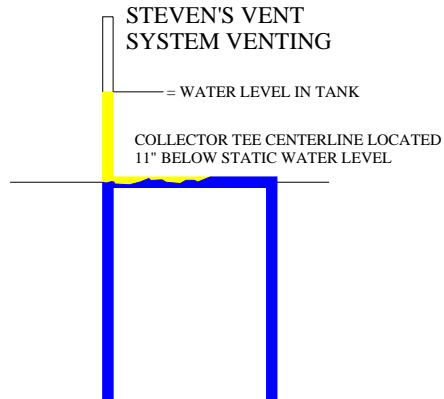

**FIGURE 9-4.**

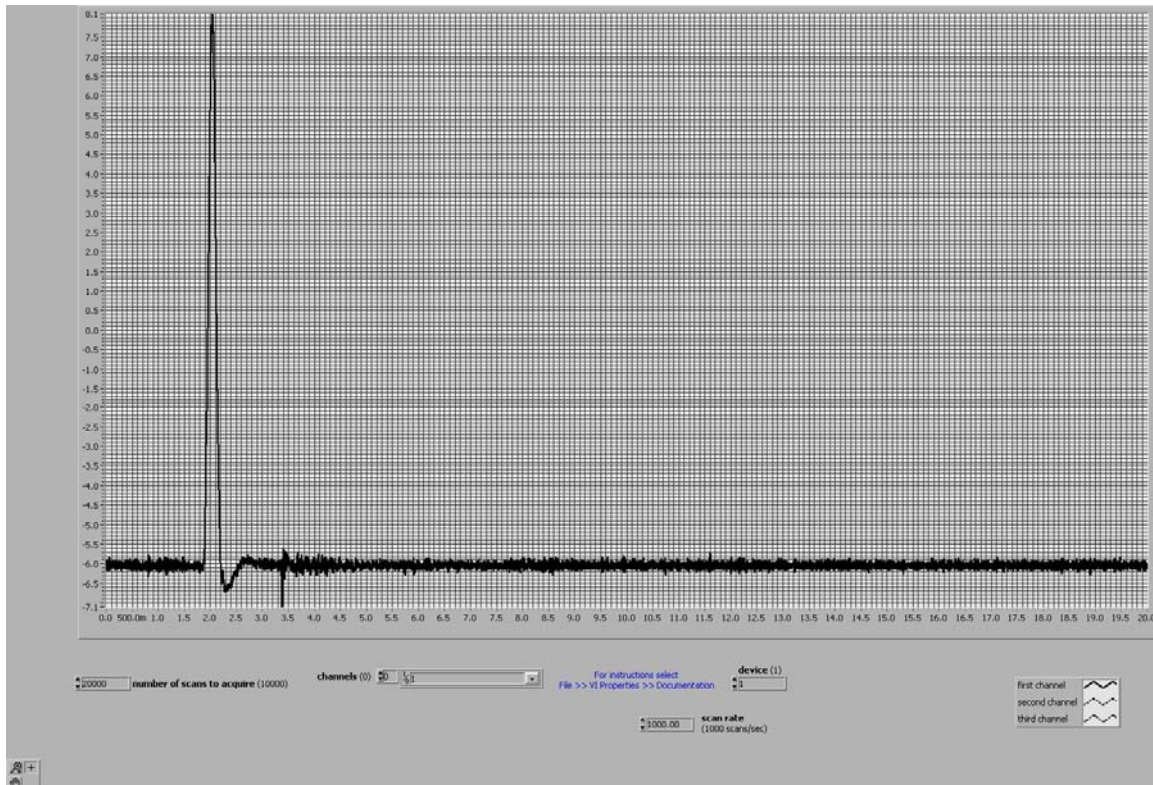

The Steven's vent pipe empties and air enters the suction piping, as shown in Figure 9-3. The blocking element is released within the required time, as shown in Figure 9-4.

# Code Compliance Incorporated

REPORT OF INVESTIGATION  
November 30, 2005

---

2. In the second series of tests the Steven's Vent system is evaluated together with dual drains utilizing a 1/2 HP pump, as shown in Figure 9. One of the dual drains is closed off via a valve. When at rest, the level of water in the vent pipe portion of the Steven's vent system is equal to the water level in the test tank, as shown in Figure 9-5. After starting the 1/2 HP pump, the water level in the vent is allowed to stabilize and as such the recorded flow is 44 gpm. The "operating draw-down" is at 6.5 inches, as shown in Figure 9-6. The other dual drain is then blocked.

**FIGURE 9-5.**

STEVEN'S VENT  
SYSTEM AT REST

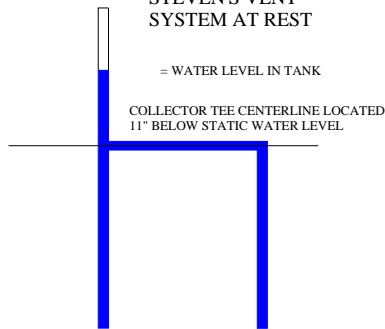

**FIGURE 9-6.**

STEVEN'S VENT  
OPERATING DRAW-DOWN

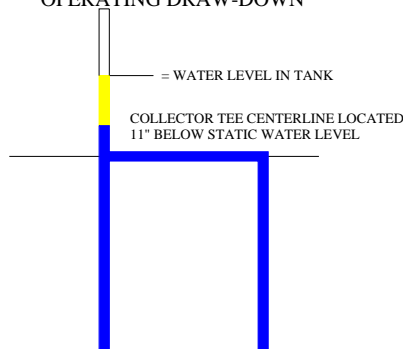

**FIGURE 9.7.**

STEVEN'S VENT  
SYSTEM VENTING

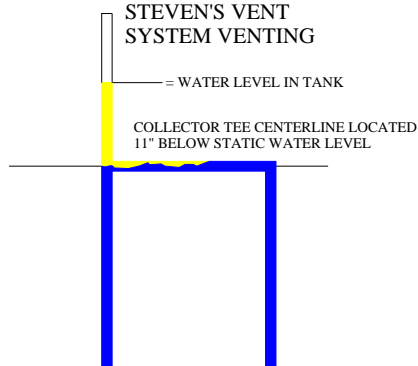



# Code Compliance Incorporated

REPORT OF INVESTIGATION  
November 30, 2005

FIGURE 9-8.

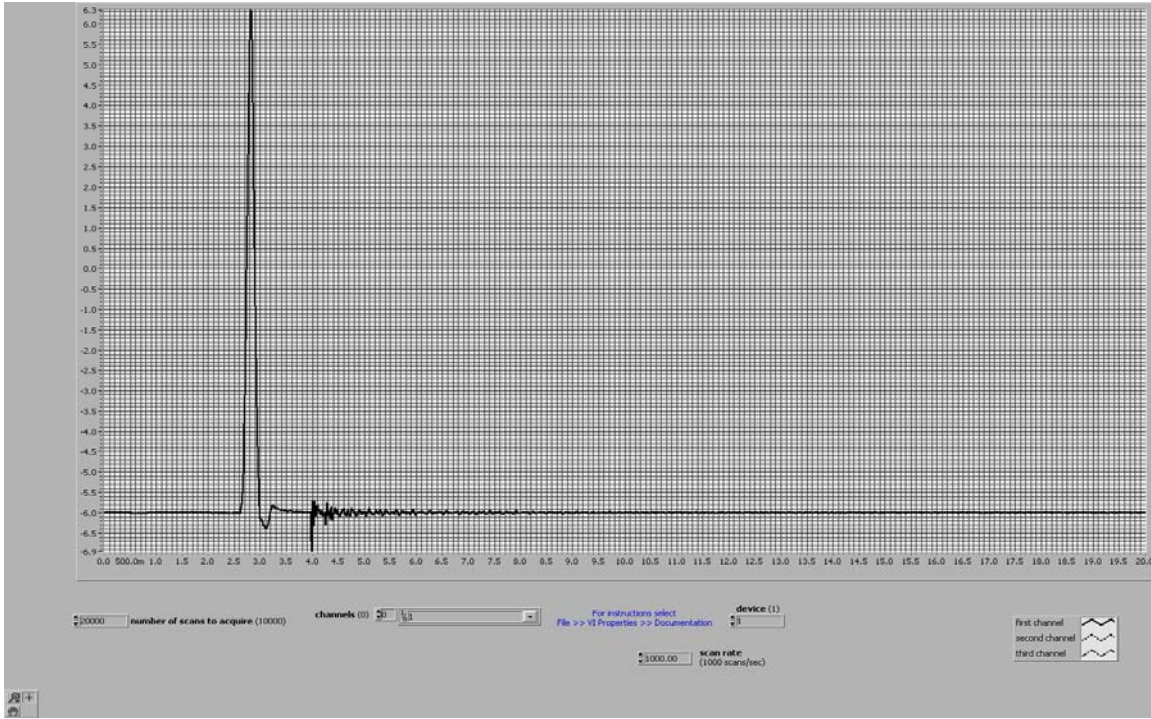

The Steven's vent pipe empties and air enters the suction piping, as shown in Figure 9-7. The blocking element is released within the required time, as shown in Figure 9-8.

3. In the third series of tests the Steven's Vent system is evaluated together with dual drains utilizing a 3HP pump, as shown in Figure 8. When at rest, the level of water in the vent pipe portion of the U-Tube vent system is equal to the water level in the test tank, as shown in Figure 9-9. After starting the 3 HP pump, the water level in the vent is allowed to stabilize and as such the recorded flow is 46 gpm. The "operating draw-down" is at 8 inches, as shown in Figure 9-10. With both of the dual drains open and flowing the other dual drain is then blocked.

The Steven's vent pipe empties and air enters the suction piping, as shown in Figure 9-11. The blocking element is releases within the required time, as shown in Figure 9-12.

FIGURE 9-9.

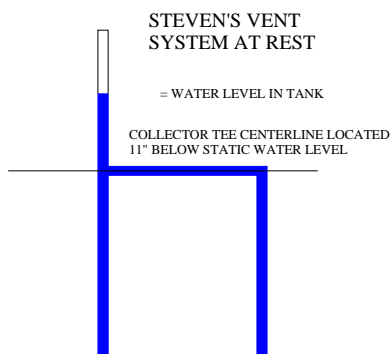
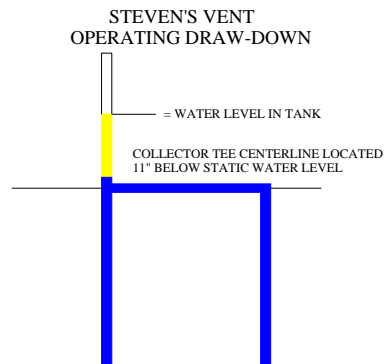

FIGURE 9-10.



# Code Compliance Incorporated

REPORT OF INVESTIGATION  
November 30, 2005

FIGURE 9-11.

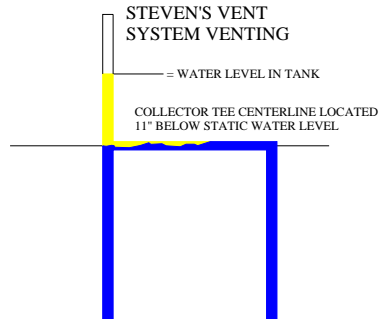
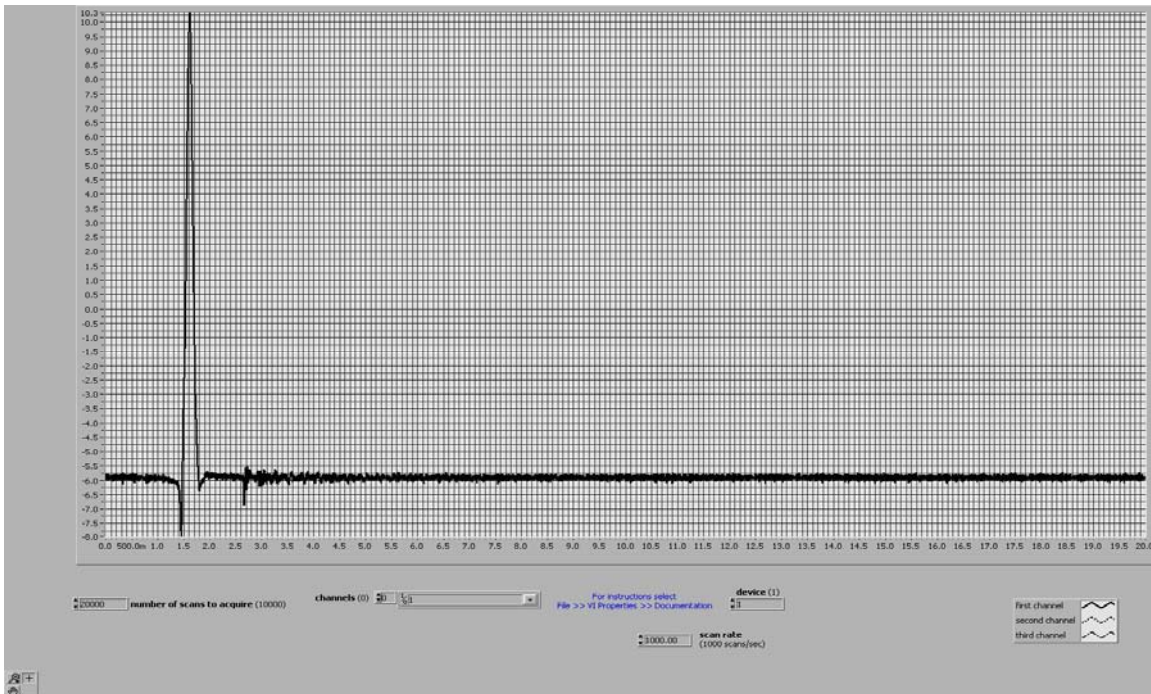

FIGURE 9-12.



4. In the fourth series of tests the Steven's Vent system is evaluated together with dual drains utilizing a ½ HP pump, as shown in Figure 9. One of the dual drains is closed off via a valve. When at rest, the level of water in the vent pipe portion of the Steven's vent system is equal to the water level in the test tank, as shown in Figure 9-13 After starting the 1/2 HP pump, the water level in the vent is allowed to stabilize and as such the recorded flow is 44 gpm. The "operating draw-down" is at 7.0 inches, as shown in Figure 9-14. The other dual drain is then blocked.

The Steven's vent pipe empties and air enters the suction piping, as shown in Figure 9-15. The blocking element is releases within the required time, as shown in Figure 9-16.

# Code Compliance Incorporated

REPORT OF INVESTIGATION  
November 30, 2005

**FIGURE 9-13.**

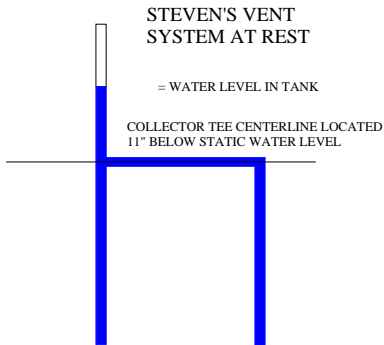

**FIGURE 9-14.**

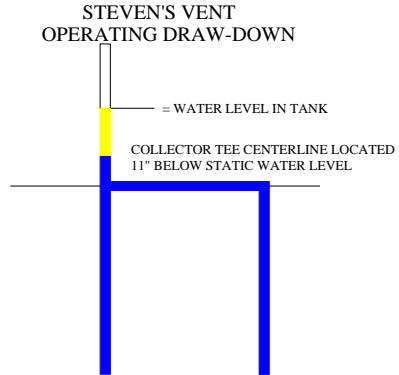

**FIGURE 9-15.**

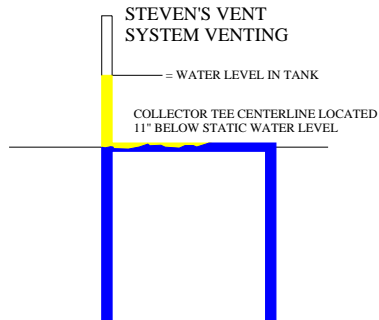

**FIGURE 9-16.**

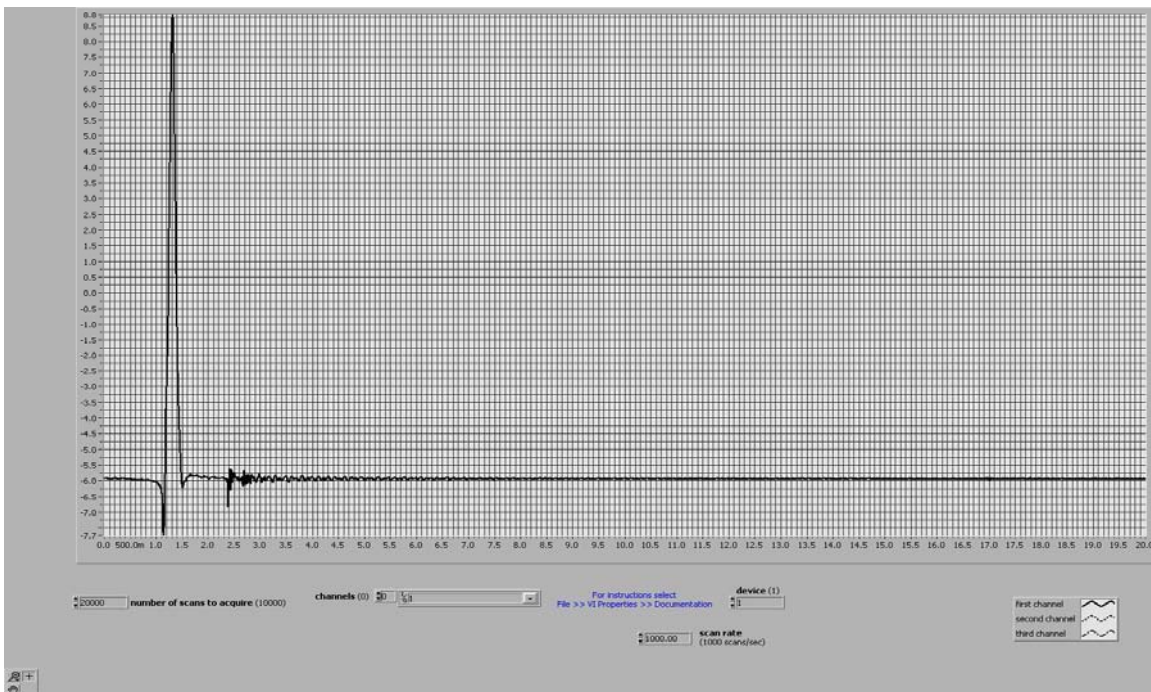

# Code Compliance

## Incorporated

REPORT OF INVESTIGATION  
November 30, 2005

---

### Conclusions – Steven’s Vent System Investigation:

The Steven’s vent together with dual drains performs within the accepted standards by releasing the blocking element within the required time under all test conditions. Flows are limited based upon piping configuration, pipe sizing, and available draw-down. The system’s collector tee is set at 11’ which equates to about fifteen pounds of static differential force on a standard 8” round (44 square inch open area) uncovered drain sump. If the collector tee is set below 11” the static differential force may not permit the blocking element to release with the required time.

### CLOSING STATEMENTS:

The 2004/2005 ICC code change cycle was concluded at the Final Action Hearings conducted by the ICC in Detroit, Michigan, during the last part of September and early October of 2005. These hearings were the last chance to effect any modifications to the 2006 set of ICC model codes. During the 2004/2005 code change cycle, the Association of Pool and Spa Professionals (APSP) [formally known as the National Spa and Pool Association (NSPI)] submitted code modifications to the International Residential Code (IRC) and the International Building Code (IBC). *See International Code Council 2004/2005 Code Development Cycle, Errata to the 2004/2005 Proposed Changes to the International Codes Item RB234-04/05, Part I – IRC and Part II – IBC*

The ICC membership rejected the APSP proposals in favor of the current code language shown above. APSP representatives argued that the options delineated in the current IBC/IRC did not address all entrapment hazards, while their proposal did. If the APSP proposals were to have been accepted they would have permitted dual drains and non-standard means as stand alone methods for entrapment mitigation. This report demonstrates that dual drains cannot be safely relied upon for entrapment prevention. The APSP proposals also included anti-entrapment methods that have not demonstrated compliance with the code-referenced ’19.17 standard.

APSP representatives have purported to address evisceration in their ICC proposals. The ’19.17 standard contains the following statement: “**WARNING: Due to the lack of physiological data, it cannot be concluded that a Safety Vacuum Release System will eliminate the potential for disembowelment. Therefore this standard does not purport to address disembowelment safety concerns.**” APSP did not present any new data to support a claim that their proposals addressed evisceration. Therefore, to date, the issue of evisceration mitigation remains largely unresolved. The reason it continues to be largely unresolved is still due to the lack of physiological data. It is interesting to note, however, that no evisceration injuries or related-deaths have been reported to date where “gravity drainage systems” are utilized with relatively large covers with flow velocities limited to less than 1.5 feet per second.

In many circumstances pool builders and enforcement personnel have relied and are relying on methods of entrapment avoidance that do not meet *any* accepted performance standard. This may prove to be problematic. This lack of accepted referenced standards for the entrapment protection systems forces enforcement personnel to require engineering for pool and spa recirculation systems. Even though such systems are sealed by an engineer, the pool builder’s, the engineer’s and enforcement personnel’s liability exposure may still exist, should a related loss occur on any non-standard system.

The International Codes are developed using the highest standards to maintain integrity of the resulting models and to insure that all materially affected interests have input. To successfully mitigate excessive liability exposure, the minimum performance levels prescribed in the International Code Council’s model codes must be adhered to.

# Code Compliance Incorporated

**REPORT OF INVESTIGATION  
November 30, 2005**

---

—**Biography** — Gary S. Duren is the proponent of record of the ICC anti-entrapment provisions contained within the latest editions of the International Building Code® and International Residential Code®, IBC Section 3109.5 and ICC Section AG106, respectively; a member of the American Society of Mechanical Engineering (ASME) A112 Committee; ASME Project Team Leader A112.19.17; Deputy Project Team Leader ASME A112.19.8; Charter member of Florida Building Commission-Plumbing Technical Advisory Committee; and member of the Florida Association of Plumbing, Mechanical and Gas Inspectors Board of Directors; as such, the opinions expressed herein are not to be construed as any official representation of any committee or board above referenced, but are solely an independent analysis provided by contract to the PSC.

***All Rights Reserved 2005 – Code Compliance, Inc...  
May not be used without written permission***